

29/30

2ABPF**F**T24S7*



2ABPF**L**O22D9*



Model	Displacement (ml/r)	Pressure(bar)		Speed(r/min)			L (mm)	L1 (mm)	Inlet			Outlet		
		Rated	Peak	Rated	Max	Min			ØD1	Ød1	T1	ØD2	Ød2	T2
2ABPF4F02T24S7*	4	200(250)	250(300)	2000	3500	500	95.5	43.3	30	13	M6	ØD2	Ød2	T2
2ABPF6F02T24S7*	6	200(250)	250(300)	2000	3500	500	99	45						
2ABPF8F02T24S7*	8	200(250)	250(300)	2000	3500	500	102	46.5						
2ABPF10F06T24S7*	10	200(250)	250(300)	2000	3500	500	105	48						
2ABPF12F06T24S7*	12	200(250)	250(300)	2000	3500	500	108	49.5						
2ABPF14F06T24S7*	14	200(250)	250(300)	2000	3500	500	111	51						
2ABPF16F06T24S7*	16	200(250)	250(280)	2000	3500	500	114	52.5						
2ABPF18F06T24S7*	18	200(250)	250(280)	2000	3500	500	117.5	54.3	40	20	M8	3	13	M6
2ABPF20F06T24S7*	20	200(250)	250(280)	2000	3500	500	121	56						
2ABPF23F06T24S7*	23	200	250	2000	3000	500	125.5	58.3						
2ABPF25F06T24S7*	25	200	250	2000	3000	500	128	59.5						
2ABPF28F06T24S7*	28	160	200	2000	3000	500	133	62						
2ABPF30F06T24S7*	30	160	200	2000	3000	500	136	63.5						

Model	Displacement (ml/r)	Pressure(bar)		Speed(r/min)			L (mm)	L1 (mm)	Inlet	Outlet
		Rated	Peak	Rated	Max	Min				
2ABPF04LJ52O22D9*	4	200(250)	250(300)	2000	3500	500	96	43.3	1-1/16-12UN-2B	3/4-16UNF-2B
2ABPF06LJ52O22D9*	6	200(250)	250(300)	2000	3500	500	98	45		
2ABPF08LJ52O22D9*	8	200(250)	250(300)	2000	3500	500	102	46.5		
2ABPF10LJ52O22D9*	10	200(250)	250(300)	2000	3500	500	104	48		
2ABPF12LJ52O22D9*	12	200(250)	250(300)	2000	3500	500	108	50		
2ABPF14LJ52O22D9*	14	200(250)	250(300)	2000	3500	500	110	51		
2ABPF16LJ52O22D9*	16	200(250)	250(280)	2000	3500	500	114	53		
2ABPF18LJ52O22D9*	18	200(250)	250(280)	2000	3500	500	117	55		
2ABPF20LJ52O22D9*	20	200(250)	250(280)	2000	3500	500	120	56		
2ABPF23LJ52O22D9*	23	200	250	2000	3000	500	123	58		
2ABPF25LJ52O22D9*	25	200	250	2000	3000	500	128	60		
2ABPF28LJ52O22D9*	28	160	200	2000	3000	500	133	63		
2ABPF30LJ52O22D9*	30	160	200	2000	3000	500	136	64		

Dimensions

2ABPF**F06T24S7*

Option: With Relief Valve

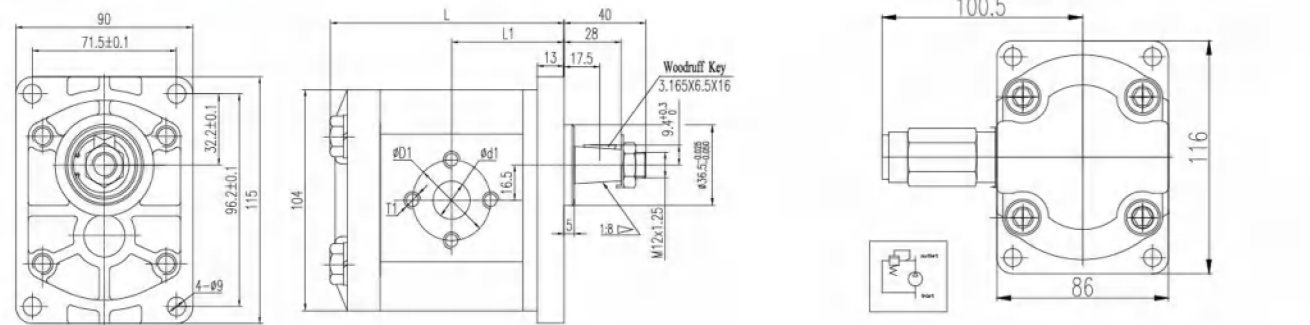

2ABPF**T49SP8L

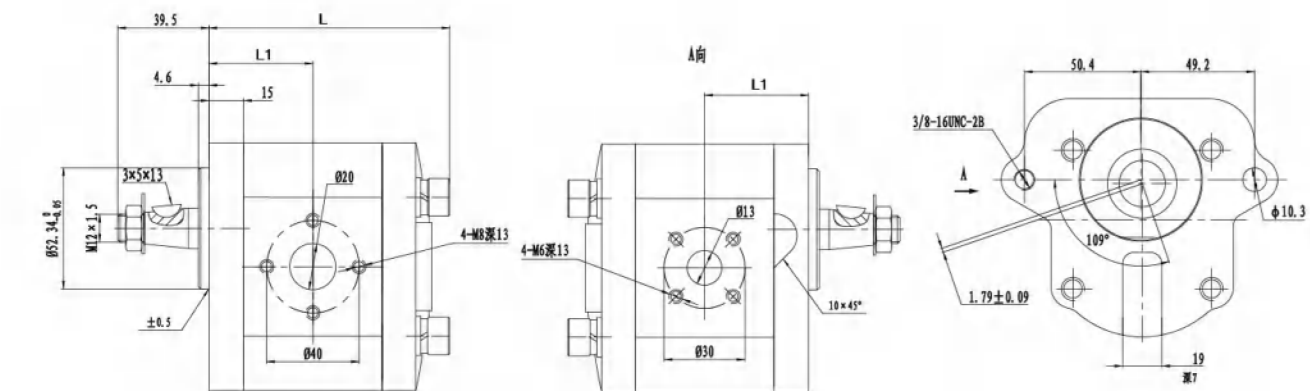

Dimensions

